

Globmetal

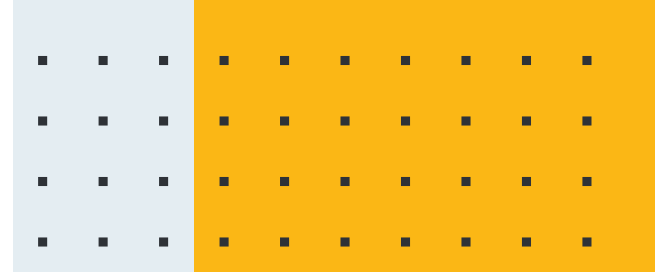

**We breathe life
into steel**

About us



We offer a wide range of metalworking services. Our priority is the highest quality of the product, but above all full customer satisfaction.

We have many years of experience in steel processing. Our experience and systematically improved qualifications of our employees, combined with a modern and developed machinery park, guarantee the highest quality of our services and allow us to implement even the most complex projects. The dynamic and flexibility in action make us stand out from the competition. Customer satisfaction is of the utmost priority for us. Because of that we are constantly improving our services.



PN-EN ISO 9001:2015



PN-EN ISO 14001:2015



PN-EN ISO 45001:2018



Our offer



Laser cutting



Bending



Straightening



Turning



Milling



Surface treatment



Manual welding



Robot welding



Fabrication services



Quality control



Design



Cooperation



Laser cutting



We provide laser cutting services using Trumpf machines, which are internationally renowned. They are characterised by high productivity and quality of the cut edge and guarantee high precision and repeatability of the cut parts.

One of the advantages of laser cutting is the wide range of materials – almost all types of sheet metal can be processed, while the thickness of the materials and the cutting area are important. Laser technology is very fast and precise, optimises the use of raw materials and allows the production of finished parts that do not require additional treatment.





Machine type

TRUMPF

TruLaser 5030 FIBER (L76)

The latest Trumpf laser equipped with a 12kW TruDisk characterised by higher cutting speeds. It can be used to cut sheets of wide range of thickness as well as to cut thicker sheets using nitrogen (oxide-free cutting on the edge). It has a CoolLine function for fine detail cutting.

Maximum thickness of material:

- construction steel 30mm,
- stainless steel 40 mm,
- aluminium 30 mm,
- copper 16 mm,
- brass 12,7 mm.

Working area:

- X axis: 3000 mm,
- Y axis: 1500 mm,
- Z axis: 115 mm.

**power
12 kW**

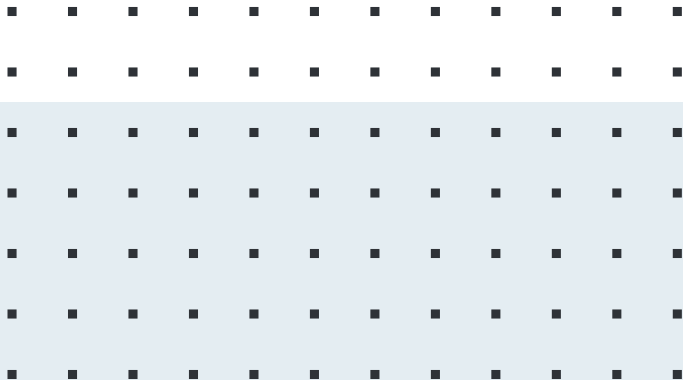



Machine type

TRUMPF

TruLaser 5030 FIBER Bright Line (L56)

5 kw laser with Fiber technology, cuts extremely fast, especially in thin sheets. The machine is designed for cutting all material grades including titanium.

Maximum thickness of material:

- construction steel 25 mm,
- stainless steel 20 mm,
- aluminium 20 mm,
- copper 10 mm,
- brass 10 mm.

Working area:

- X axis: 3000 mm,
- Y axis: 1500 mm,
- Z axis: 115 mm.

**power
5 kW**

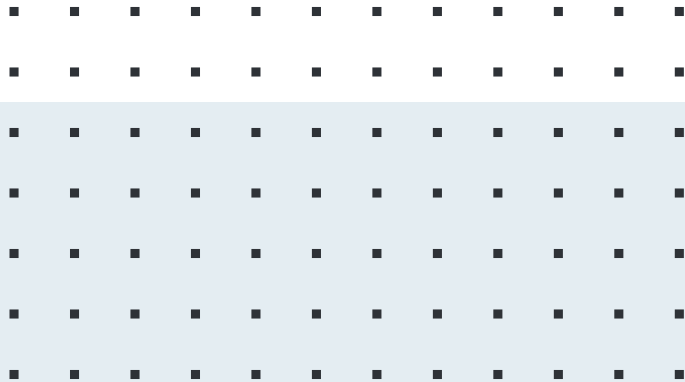



Machine type

TRUMPF

TruLaser 5030 FIBER (L41)

Laser w technologii Fiber o mocy 5 kW, wyjątkowo szybko wykonuje cięcia zwłaszcza w cienkich blachach. Maszyna przeznaczona do cięcia wszystkich gatunków materiałów w tym również tytanu.

Maksymalna grubość materiału:

- stal konstrukcyjna 25 mm,
- stal szlachetna 20 mm,
- aluminium 20 mm,
- miedź 10 mm,
- mosiądz 10 mm.

Strefa robocza:

- X axis: 3000 mm,
- Y axis: 1500 mm,
- Z axis: 115 mm.

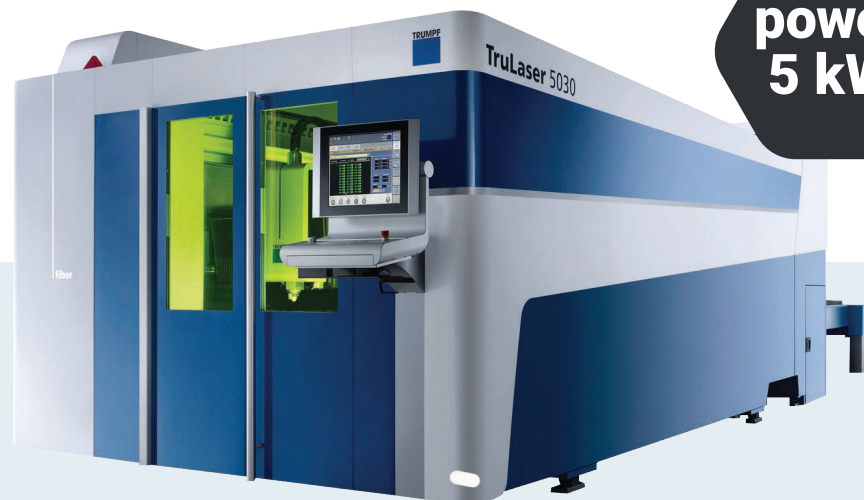

**power
5 kW**

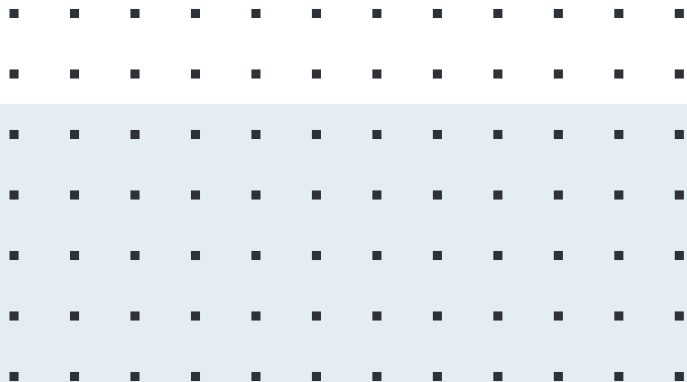



Machine type

TRUMPF TruLaser 3030 (L20)

CO2 laser technology means high power combined with cutting quality. TruFlow CO2 laser is ideal for thin stainless steel. It is also characterised by an improved quality of the burnt edge of thick construction sheets.

Maximum thickness of material:

- construction steel 25 mm,
- stainless steel 20 mm,
- aluminium 12.7 mm.

Working area:

- X axis: 3000 mm,
- Y axis: 1500 mm,
- Z axis: 115 mm.

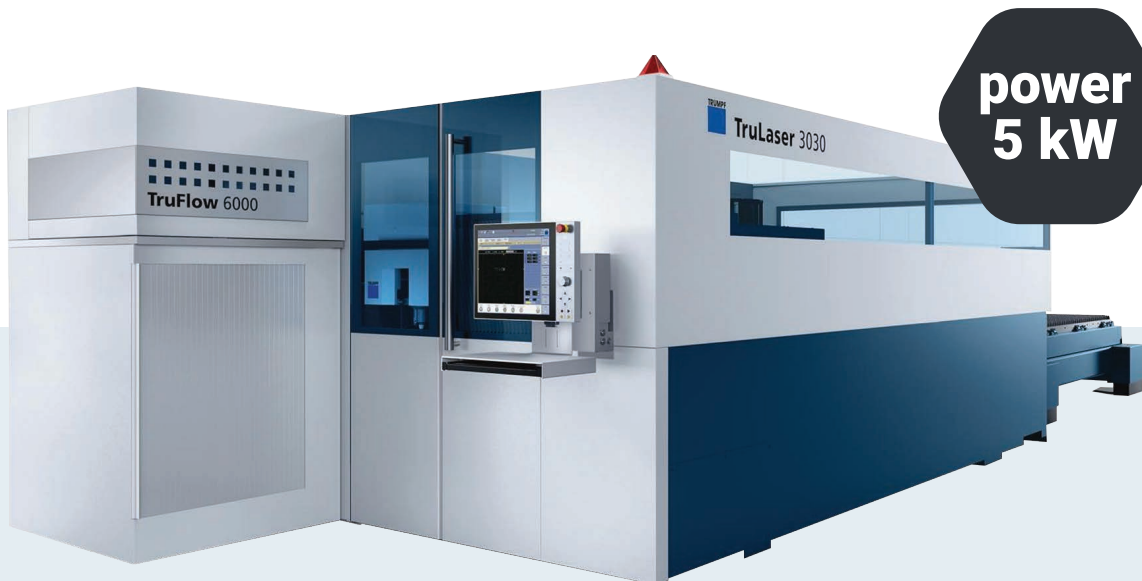

Machine type

TRUMPF LiftMaster Compact



The use of the LiftMaster Compact system allows for fully automated loading and unloading of sheets. This solution significantly affects the laser efficiency and production optimization. In case of serial production, it significantly reduces the manual operation in the process.

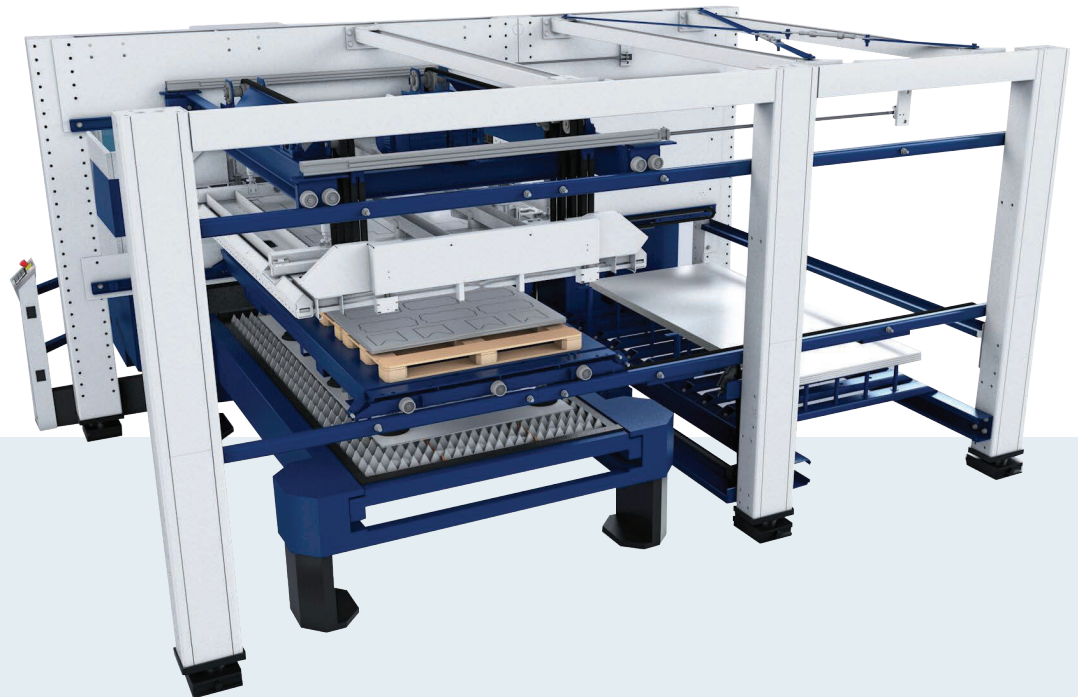

Machine type

TRUMPF

LoadMaster



The universal loading unit LoadMaster automatically supplies the machine with sheets of raw material. The automation system ensures process safety and high productivity.

Technical data:

- max. sheet format: 3000 mm x 1500 mm,
- min. sheet format: 1000 mm x 1000 mm,
- max. sheet thickness: 25 mm,
- max. sheet weight: 900kg.

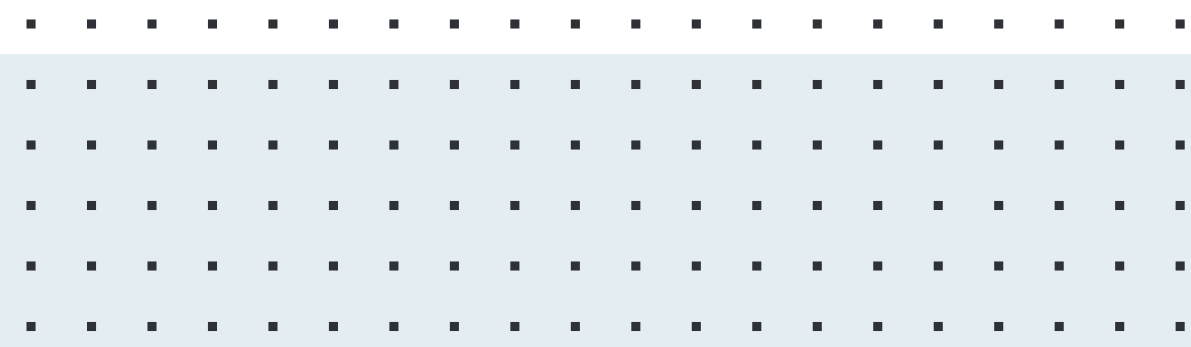
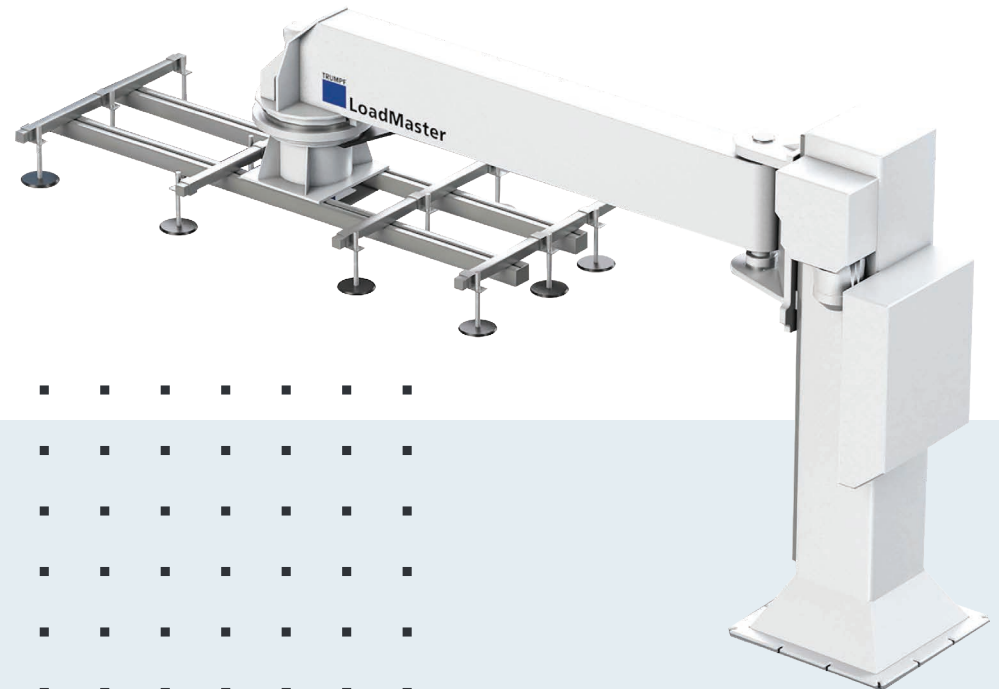

Did you know...?



Nearly

10 million

workpieces a year

are produced in our
laser cutting department





Bending

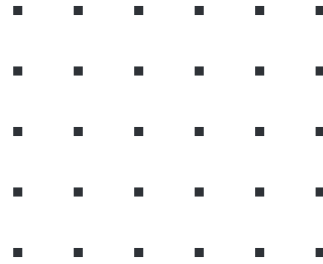

We provide a service of workpiece bending using two Trumpf press brakes. Numerical control guarantees exceptional precision and repeatability of shapes. With these machines, we can produce both simple and complex components in any format. We are capable of preforming segmental and radial bends as well as folds.

When expanding the machinery in the press brake department, we are following developments in technology, which is why most of the presses are servo-electrically driven. We currently have six press brakes with a maximum reach of three metres.

This allows us to deliver precisely manufactured parts to our customers in a very short time.

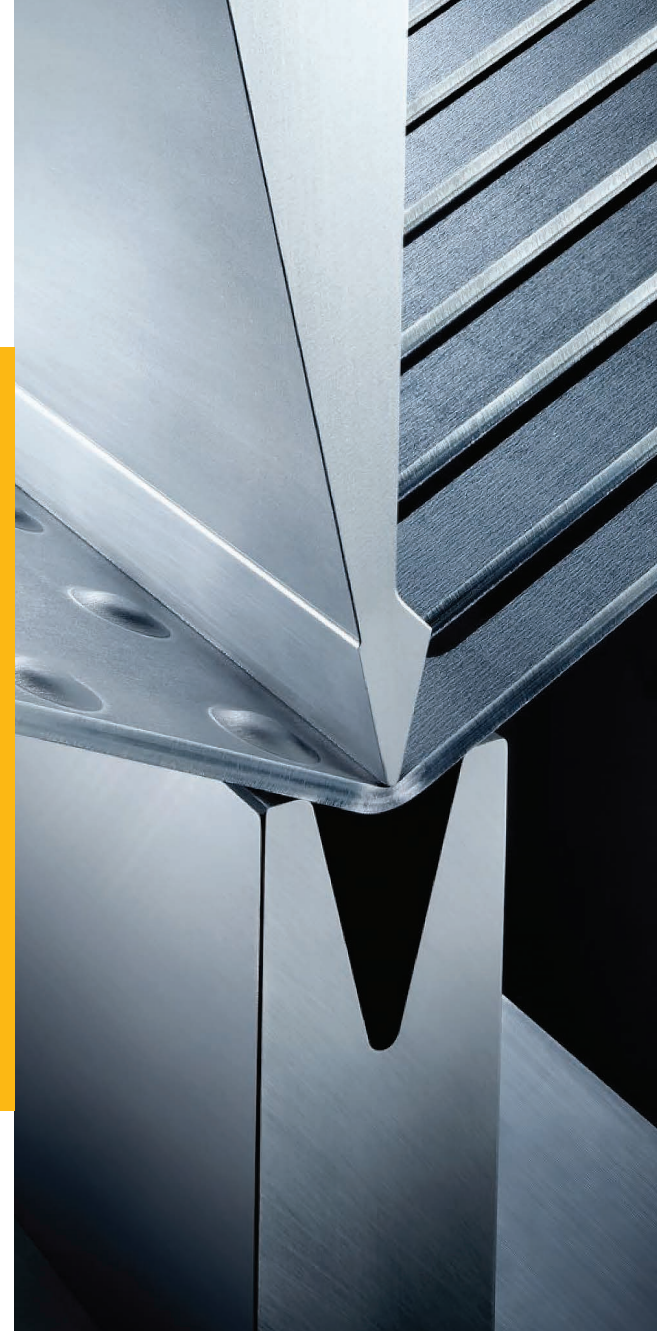
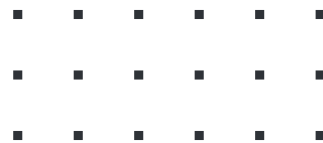

Machine type

TRUMPF

TruBend 5085



TruBend 5085 is the newest press brake in our bending department. It is valued for high precision, accuracy, repeatability and efficiency.

Technical data:

- pressure of 85 tons,
- bending edge length 2210 mm,
- free through hole 1750 mm,
- useful installation height 385 mm,
- overhang 420 mm,
- maximum Y-axis speed in operating mode 25 mm/s.

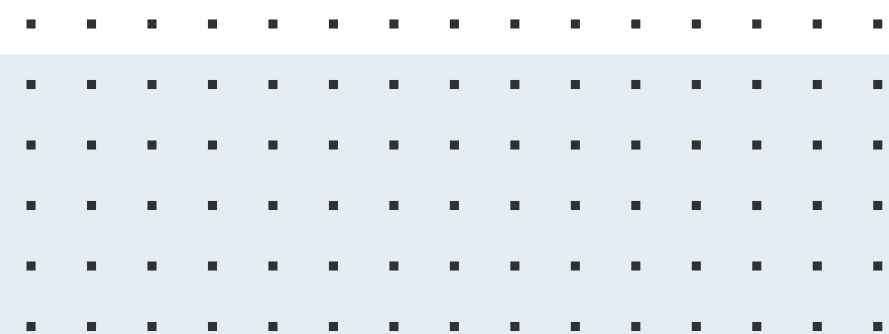

Machine type

TRUMPF

TruBend 5170



TruBend 5170 brake press brake is the most powerful machine in our bending department. It offers reliability combined with speed and versatility. It is equipped with a control system that allows precise bending of sheets of varying thicknesses and lengths.

Technical data:

- pressure of 170 tons,
- bending edge length 3230 mm,
- free through hole 2690 mm,
- useful installation height 615 mm,
- overhang 415 mm,
- maximum Y-axis speed in operating mode 25 mm/s.

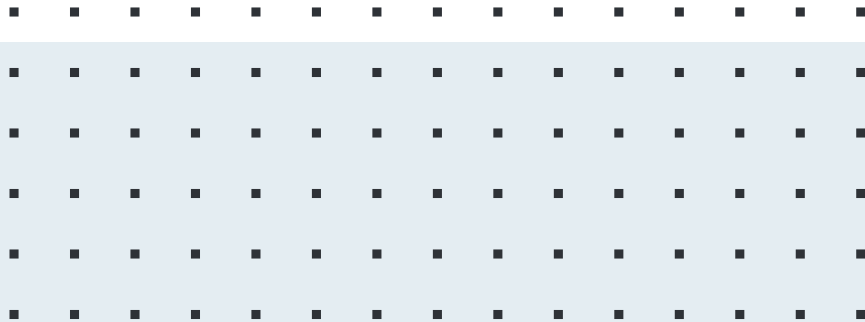

Machine type

TRUMPF

TruBend 7050



The servo-electric press brake is characterised by its high speed in operation. It is designed for thin sheet metal parts. It is ideal for series production.

Technical data:

- pressure of 50 tons,
- bending edge length 1520 mm,
- high feed speed 220 mm/s,
- maximum working speed 25 mm/s.

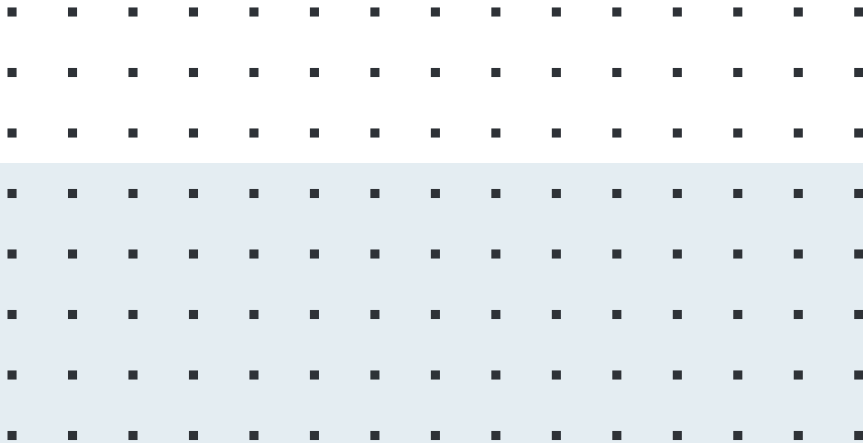

Machine type

TRUMPF TruBend 7036



TruBend 7036 brake press brake is another servo-electric machine in our bending department. It features an advanced control system that allows easy programming and adjustment of the bending process. It is ideal for large series of small parts.

Technical data:

- pressure of 36 tons,
- bending edge length 1020 mm,
- high feed speed 220 mm/s,
- maximum working speed 10-25 mm/s.

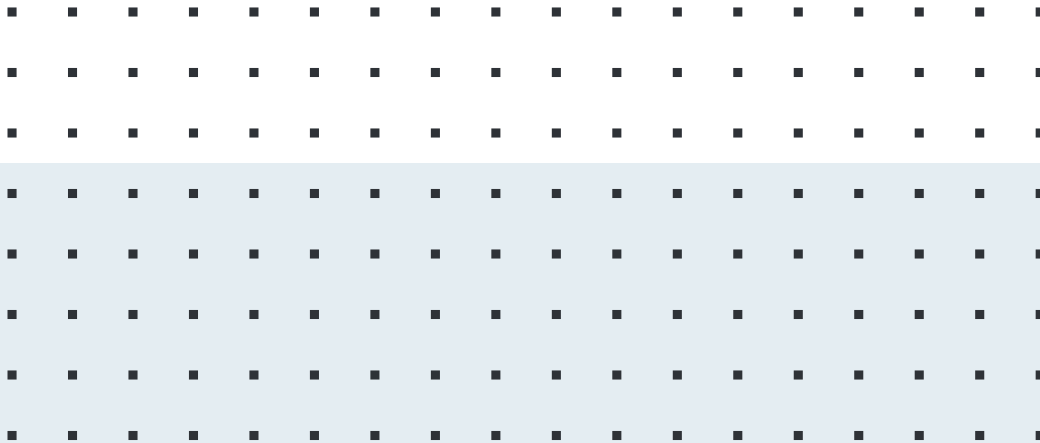

Machine type

TRUMPF

TruBend 3120



The TruBend 3120 hydraulic press brake is a universal machine for bending workpieces of different thicknesses. It provides high precision while maintaining productivity. Easy programming and adjustment of the bending process.

Technical data:

- pressure of 122 tons,
- bending edge length 3110 mm,
- bending of sheets with a thickness of 0.5 up to 12 mm,
- automatic compensation of deflection of the lower beam.

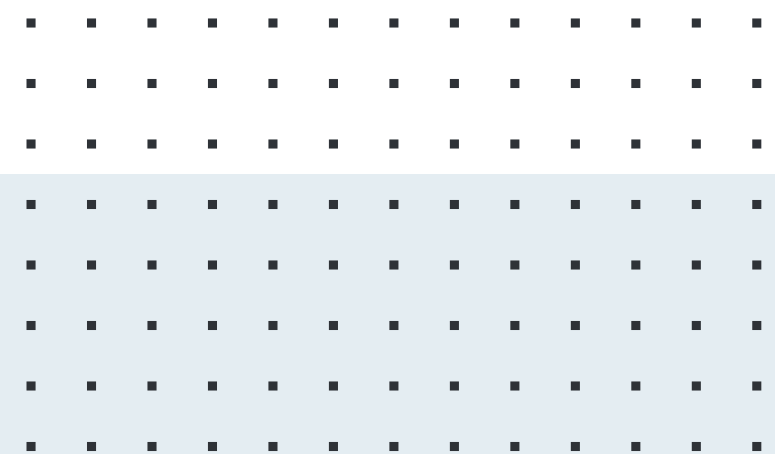

Machine type

TRUMPF

TruBend 3100



The TruBend 3100 press brake offers high precision and performance. One of its greatest strengths are automatic functions, such as quick and easy tool changes and automatic setting of the bending position.

Technical data:

- pressure of 102 tons,
- bending edge length 3060 mm,
- high feed speed 200 mm/s,
- maximum working speed 15 mm/s.

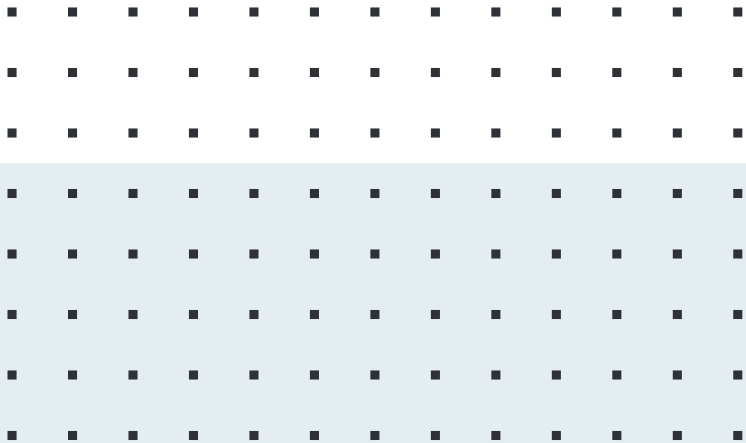



Straightening



Straightening workpieces after heat treatment is an uncommon process on the market, although it gives surprising results.

It is mainly about releasing deformation of laser cut parts to achieve the expected flatness, even for high-strength parts, meeting very demanding standards.

The process of straightening materials after laser cutting is not required, however it is very cost-effective and offers great convenience in subsequent production stages. This allows to accelerate the subsequent processing of elements in the process of welding, bending and milling.

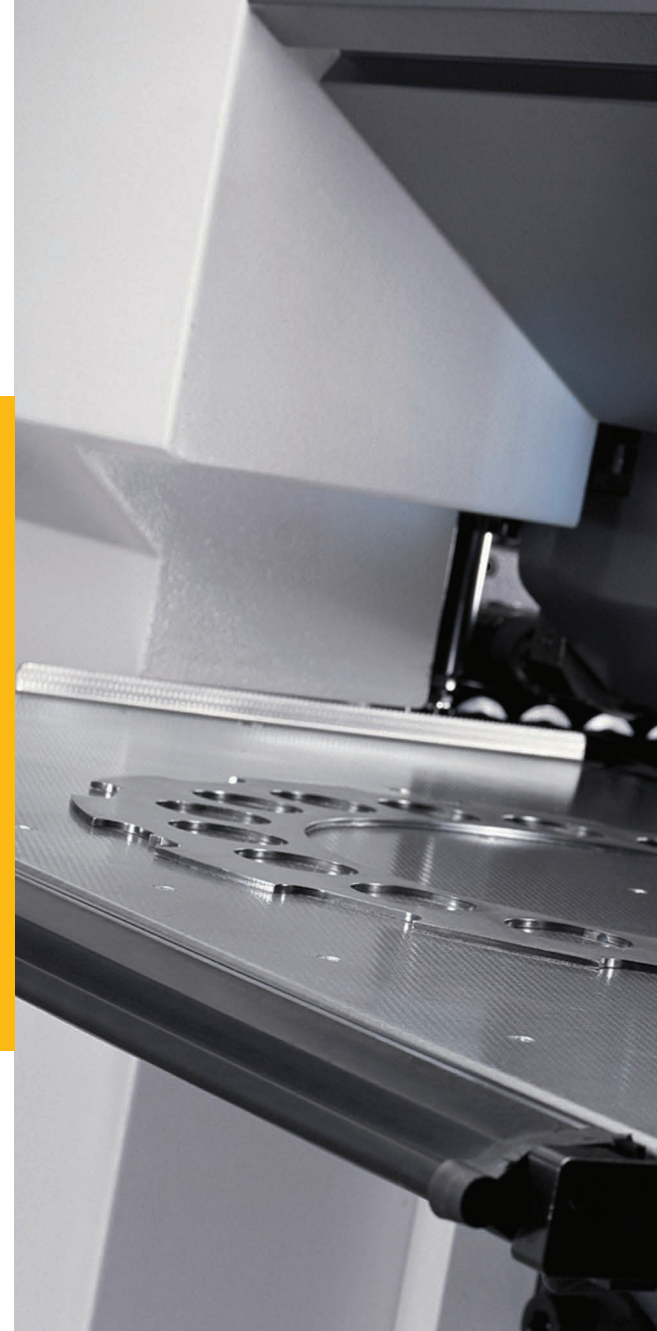



Machine type

ARKU FlatMaster* 55 165

ARKU FlatMaster precision straightener* 55 165 is an advanced sheet metal straightening machine. It has a state-of-the-art control system that allows easy and precise setting of the relevant working parameters.

Technical data:

- 19 straightening rollers,
- 231 supporting rollers,
- inlet height: approx. 950 mm
- speed: 3 to 12 m/min, speed adjustable.

Performance:

- max. thickness of workpiece: 15 mm,
- max. width of workpiece: 1650 mm,
- max. length of workpiece: 100 mm,
- adjustment accuracy: 0.01mm.

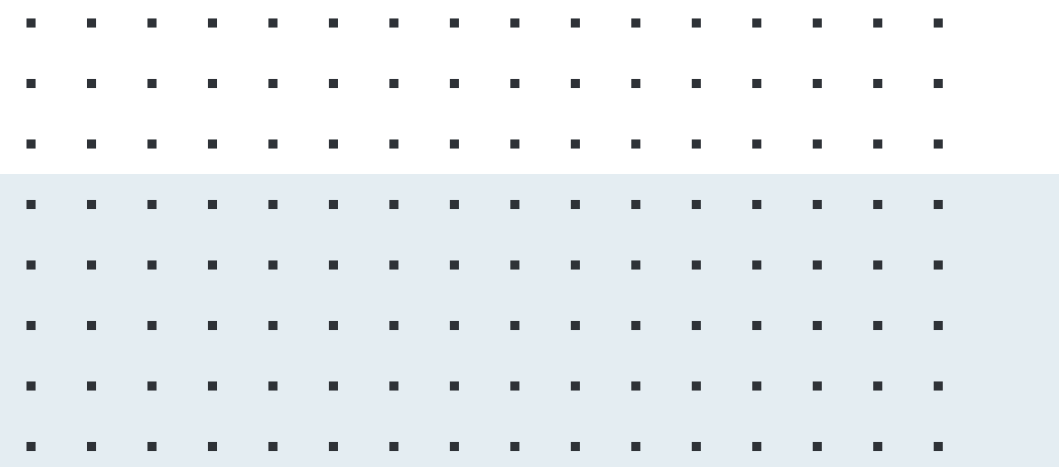



Surface treatment

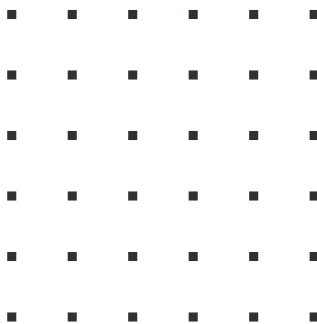

In the surface treatment department, we have machines that allow us to improve the surface quality of manufactured parts. Costa wide-belt grinders improve the finishing process of parts cut with laser. They remove sharp edges, burrs, oxide cutting deposits and splatter. The main advantages of using Costa grinders are the high repeatability of the workpieces and the increase in working speed, as well as the reduction in dust and noise.

In case of small workpieces we offer vibro abrasive machining to mechanically remove contaminants and imperfections from the sheet metal surface using special abrasive compounds and vibration. This process is used to obtain a uniform and smooth surface on the workpieces and to reduce the time required for manual grinding.

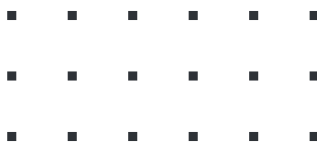



Machine type

COSTA MD4 CVV 1150 BS

Wide-belt grinder designed for grinding workpieces made of black steel. The machine can be used for blunting and rounding sharp edges as well as removing oxide deposits, which is extremely useful prior to painting and chemical treatment. Due to the use of a magnetic table, it is possible to process small workpieces.

Technical data:

- working width: up to 1150 mm,
- table height: 750-900 mm,
- weight:
 - 1800 kg with two units,
 - 2300 kg with three units.





Machine type

COSTA MD4 CVV 1150 SS

Another wide-belt grinder designed for grinding workpieces made of stainless steel. The machine can be used for blunting and rounding sharp edges of laser-cut workpieces and finishing them.

Technical data:

- working width: up to 1150 mm,
- table height: 750-900 mm,
- weight:
 - 1800 kg with two units,
 - 2300 kg with three units.





Machine type

RÖSLER

Rotary Vibrator, Rotary Dryer, Centrifuge

Rösler technology is a proven, high-performance method of surface finishing. The machine is equipped with optimum technological solutions that enable automated, chain-based work processes.

- **Rotary Vibrator** – Rosler circular vibrator for vibro abrasive machining.
- **Rotary Dryer** – energy-efficient Rosler wheel dryer for drying workpieces in organic granules.
- **Centrifuge** – Rosler semi-automatic decanter centrifuge for treatment of process water in a closed system.

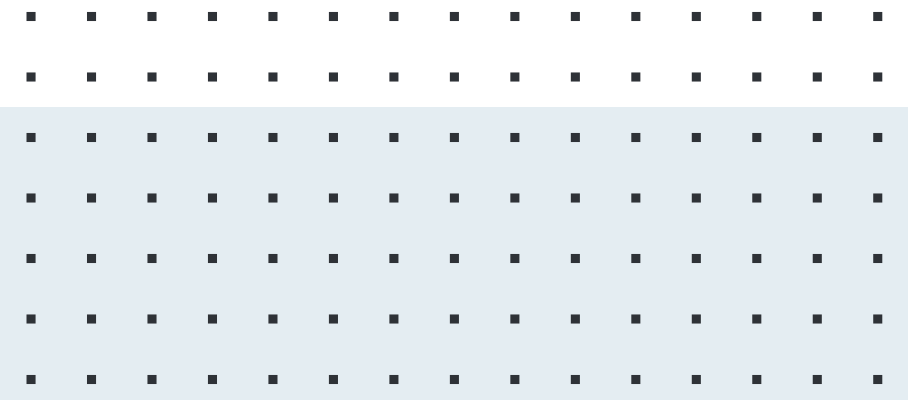



Turning

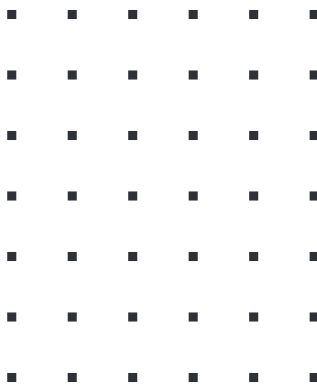

In terms of turning services using numerically controlled technology, we offer Customers the use of DMG MORI machine tools. The use of these machines allows for the machining of both simple components and more complex series, thus adapting to individual Customer needs.

With specialised tools, we are able to carry out complete processing of complex components, including full-surface treatment. In addition, by using improvements such as the bar feeder, we can significantly increase productivity by automating the entire process.

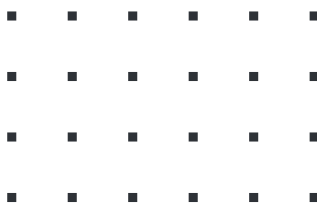

Machine type

DMG MORI CTX 510



The DMG MORI CTX 510 is an advanced multifunctional turning machine designed for processing metal parts with complex geometries. The machine offers multiple functions including turning, drilling, tapping, milling and thread cutting. It is equipped with pivoting heads to process workpieces at different angles.

Technical data:

- turning diameter Ø465 mm,
- passage in the spindle up to Ø90 mm, ensuring flexibility during machining of workpieces,
- Y-axis ensures efficient turning and milling in one mounting,
- 12-position VDI tool head.



Machine type

DMG MORI CLX 450



The DMG MORI CLX 450 is a multipurpose machine in a compact design with a large working area, used for machining customised parts.

Technical data:

- turning diameter $\text{Ø}400$ mm,
- maximum length of a workpiece with the tailstock (with machining possibility) 800 mm,
- maximum handle size 315 mm,
- maximum spindle speed 4000 rpm,
- maximum internal diameter of the clamping pipe $\text{Ø}80$ mm.

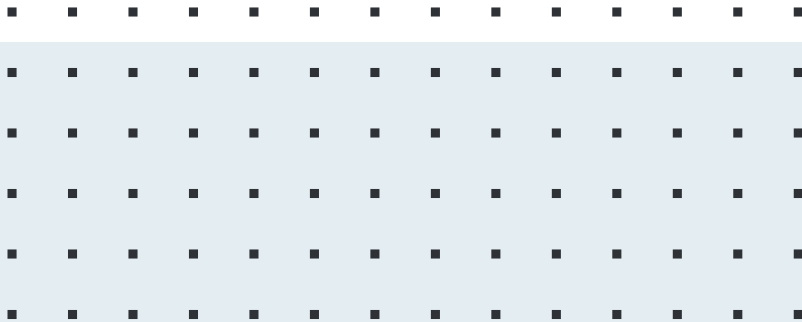
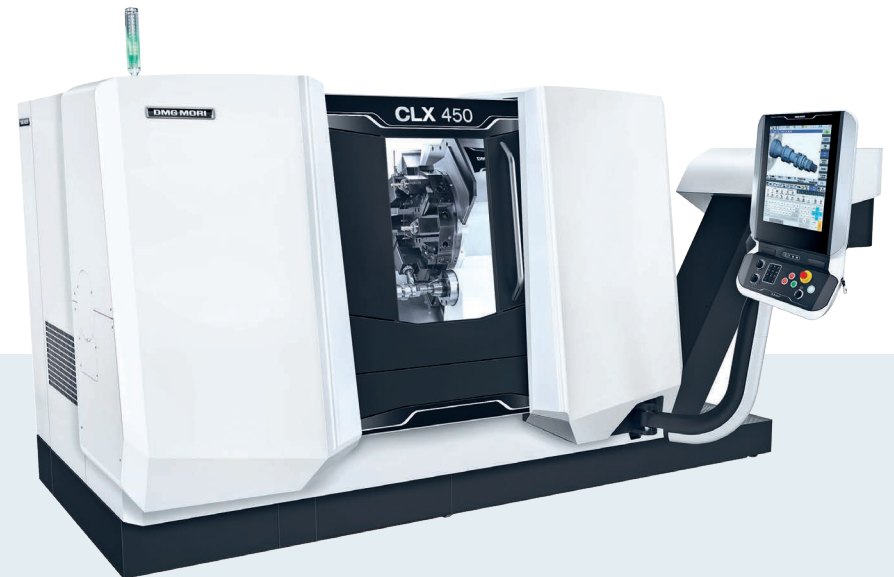

Machine type

DMG MORI CTX 450



DMG MORI CTX 450 is another machine in our turning division. The machine has been designed to provide high productivity and precision processing, as well as ease of use, making it ideal for medium series production.

Technical data:

- turning diameter Ø400 mm,
- passage in the spindle up to Ø75 mm,
- max. length of workpiece: 1050 mm,
- maximum spindle speed 4000 rpm,
- 12-position VDI tool head.

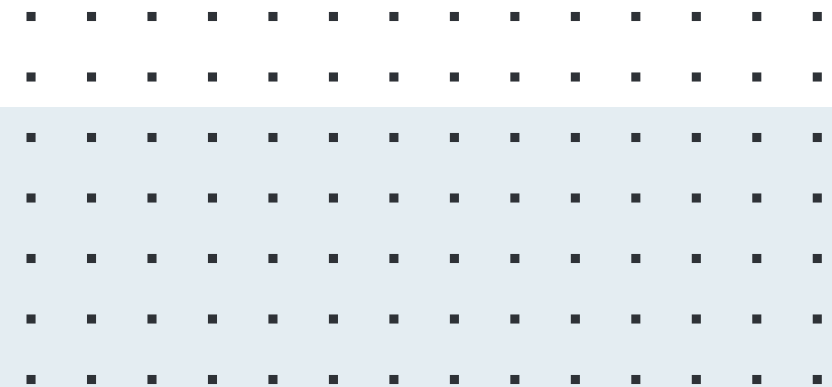



Machine type

DMG MORI CLX 450 - z przeciwwrzcieniem

This is the second machine in the CLX series, with an additional counter-spindle. With this solution it is possible to set up production for both sides of the workpiece, without the need for manual adjustments.

Technical data:

- turning diameter $\varnothing 400$ mm,
- maximum length of a workpiece with the tailstock (with machining possibility) 800 mm,
- maximum handle size 315 mm,
- maximum spindle speed 4000 rpm,
- maximum internal diameter of the clamping pipe $\varnothing 80$ mm.

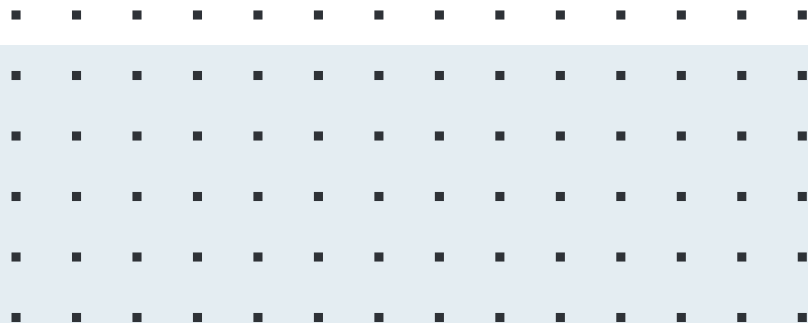

Machine type

IEMCA KID 80+ bar feeder



The KID 80+ is an automatic high-performance short bar feeder, ideal for applications on fixed headstock CNC lathes, even equipped with the sub-spindle. The KID 80+ can handle short bars with diameters between 5 to 80 mm, for bar lengths from 90 to 1.615 mm. It is simple to use, robust and featured by the sub-spindle mode.



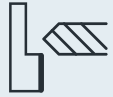

Milling



Machining services are provided using DMG MORI vertical milling machines, offering top advanced milling technology, equipped with state-of-the-art cooling systems and powerful spindle systems to expand the range of processed workpieces.

Milling is one of the most versatile machining processes, making it possible to manufacture parts with complex geometries and to process materials of different hardness.

Our machinery provides precise programming and control of the milling process. We are able to produce high-quality parts and minimise production times.

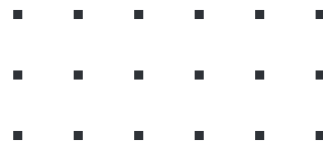

Machine type

DMG MORI CMX 1100 V



DMG MORI CMX 1100 V is a state-of-the-art milling machine with the highest level of precision. It is characterised by a small setting area and a large working area.

Technical data:

- maximum axis-X feed 1100 mm,
- maximum axis-Y feed 560 mm,
- maximum axis-Z feed 510 mm,
- maximum table load 1000 kg.

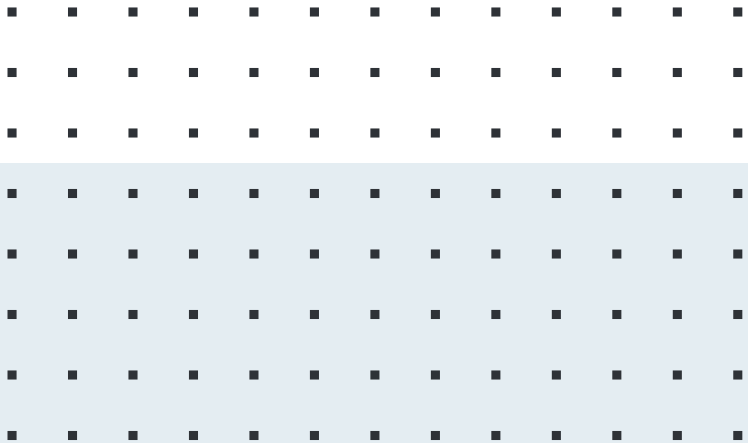

Machine type

DMG MORI

DMF 260



The impressive DMG MORI DMF 260 is a modern 5-axis machining centre with a table length of 2.6m. It is used for precision processing of metals, plastics and other materials. This machine is characterised by high accuracy, reliability and speed.

Technical data:

- maximum axis-X feed 2600 mm,
- maximum axis-Y feed 700 mm,
- maximum axis-Z feed 700 mm,
- rotation speed 18,000 rpm.

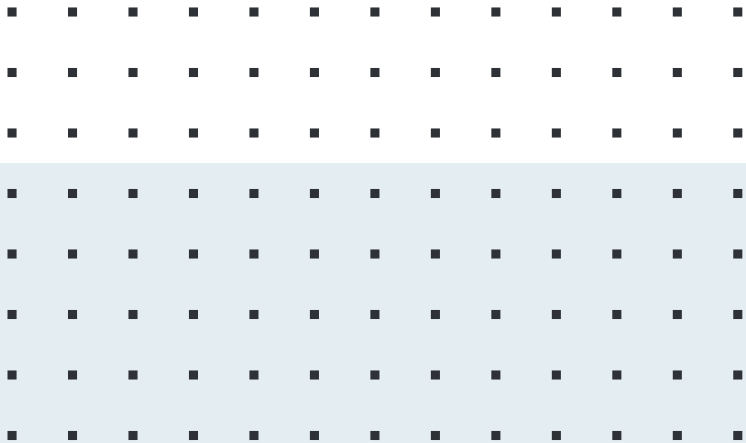

Machine type

DMG MORI

DMX 60*



The latest series of high-performance, and above all, precise and versatile milling centres. Thanks to the Speed Master spindle 20.000 rpm and automation solutions, production efficiency can be significantly increased.

Technical data:

- maximum travel along the X-axis: 600 mm,
- maximum travel along the Y-axis: 600 mm,
- maximum travel along the Z-axis: 510 mm,
- rotational speed: 20000 rpm.

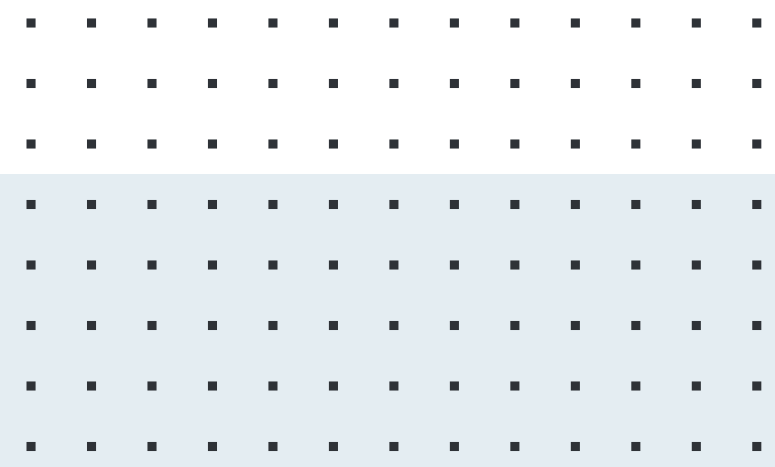

Machine type

DMG MORI

DMX 80*



An ultra-fast and precise milling centre. The DMX range stands out from the competition thanks to its excellent rigidity, performance, and thermal stability.

Technical data:

- maximum travel along the X-axis: 800 mm,
- maximum travel along the Y-axis: 600 mm,
- maximum travel along the Z-axis: 510 mm,
- rotational speed: 20000 rpm.

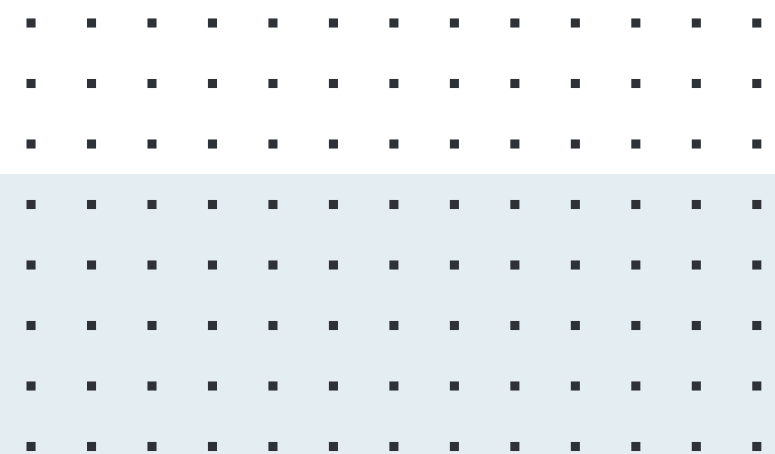

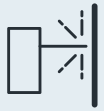

Spawanie manualne



We offer TIG, MIG, MAG manual and automated welding of the highest quality. We carry out welding of structural steels, alloy steels and aluminium and its alloys. A good engineering team, experienced welders and available machinery allow us to comprehensively carry out even very complex projects.



We are ISO-certified in the field of welding

- PN-EN ISO 3834-2
- PN-EN 1090

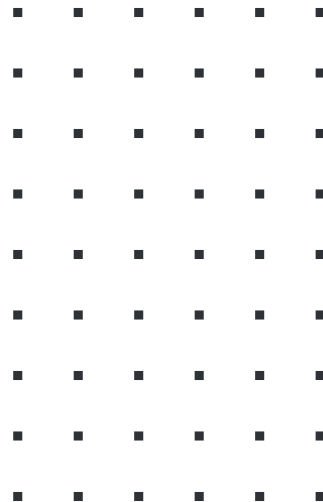

Service type

Manual welding



We offer welding services: TIG, MIG, MAG.

We perform welding of constructional steels, alloy steels and aluminium and its alloys.

In our machinery we have:

- Migatronic welding machines,
- Kempi welding machines,
- Fronius CMT welding machines,
- Siegmund welding tables,
- Lizardm welding trolley,
- Kemper filtration system.



siegmund





Robot welding

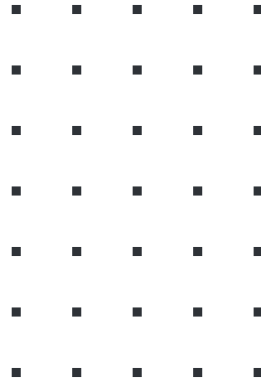

Robot welding provides precise and fast results, reduces waste and improves safety. Robots can reach inaccessible areas and accurately perform complex welds faster than manual processes.

The robot welding process not only increases productivity, but above all guarantees the repeatability of the process, reducing the risk of errors.

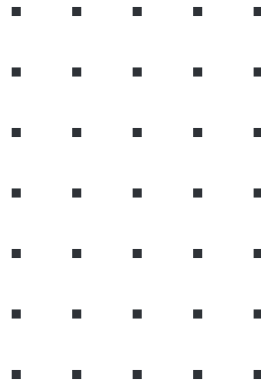



Machine type

Two ABB IRB 1600

The IRB 1600 industrial robots are the most powerful robots in their class on the market, guaranteeing high quality welded parts. The machine provides exceptional positioning repeatability and high trajectory reproduction accuracy. Each robot is additionally equipped with positioners with different working area ranges.

Technical data:

- arc welding,
- repeatability of positions up to 0.02 mm,
- repeatability of tracks up to 0.48 mm,
- simplified robot software considerably reduces lead times and improves the quality of orders.

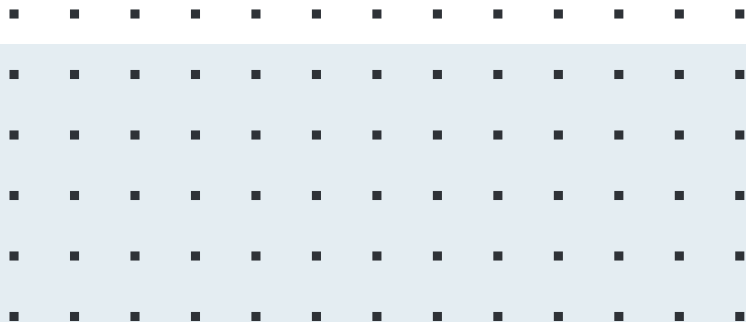



Machine type

6-axial robot MOTOMAN AR3120

The Yaskawa robot provides the widest range of motion of the entire AR series, as well as high path accuracy to best optimise arc welding. The wide range of motion supports the welding of large and complex structures. The robot is installed on a 12 meters track allowing it to travel between two stations thus optimising changeover times.

Technical data:

- number of axes: 6,
- lifting capacity: 20 kg,
- maximum working range: 3,124 mm,
- repeatability: 0.07 mm,
- weight: 560 kg,
- power supply: 2 kVA.

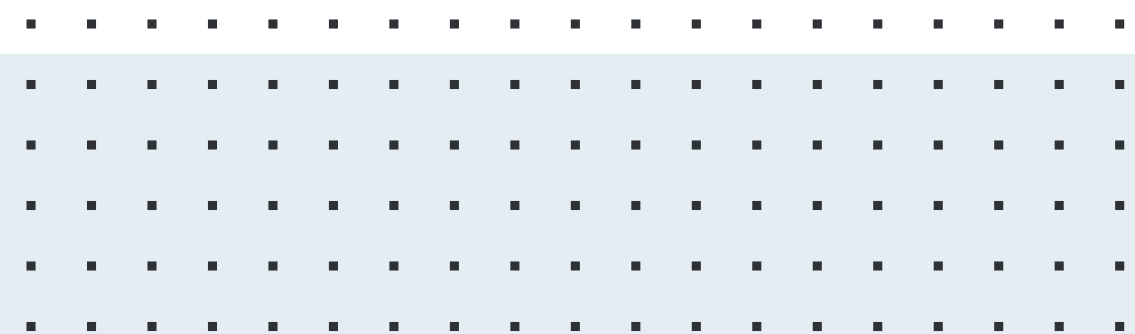



Fabrication services

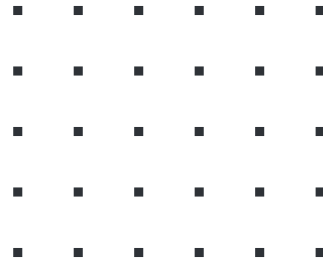

We have an extensive machinery, so we can carry out various types of fabrication services.

We offer:

- riveting,
- spot welding,
- capacitor welding,
- pressing of PEM-type fasteners,
- blind rivets,
- bevelling,
- threading,
- drilling,
- grinding,
- rolling,
- cutting with band saws.

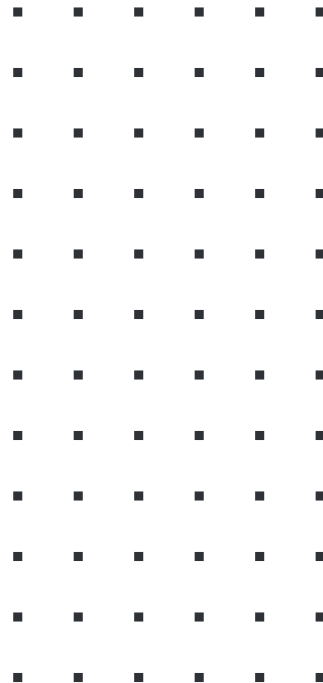



Machine type

HAEGER machine 824-MSP-5E

HAEGER Machine 824-MSP-5E is an automatic machine for inserting spacers into holes in various materials such as black steel, aluminium, plastics and others.

Technical data:

- force range from 800 to 16,000 pounds (3.6 to 72 kN),
- stroke length from 0 to 8.5 inches (0 to 220 mm),
- speed up to 2000 insertions per hour,
- repeatability +/- 2% of force setting.

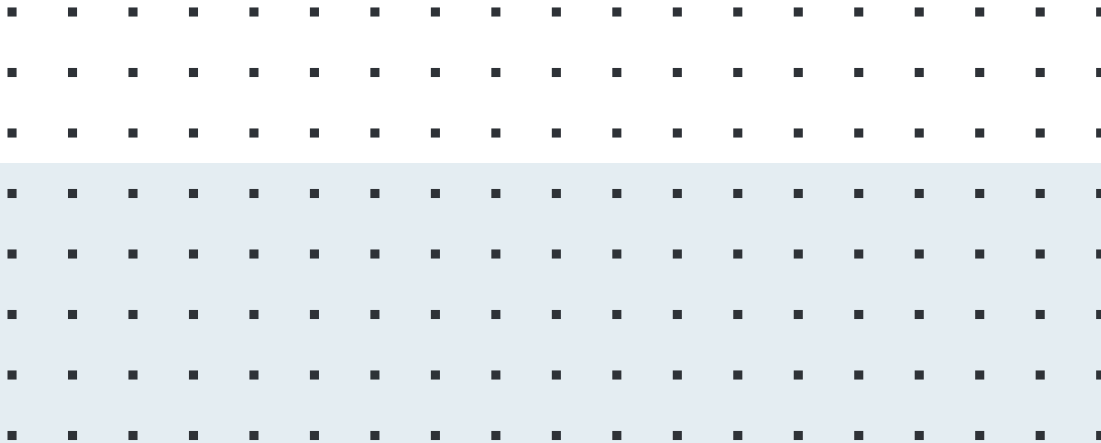



Machine type

Bandsaw BEKAMAK BMSO 540 CGH

Automatic cutting-off machine for cutting materials with larger diameters. This machine is used for cutting sections and solid materials such as shafts and blocks.

Technical data:

- cutting range of round elements: 540 mm,
- cutting range of rectangular elements: 720x540 mm at 90°,
- rotation of the arm from 90° up to +30°.

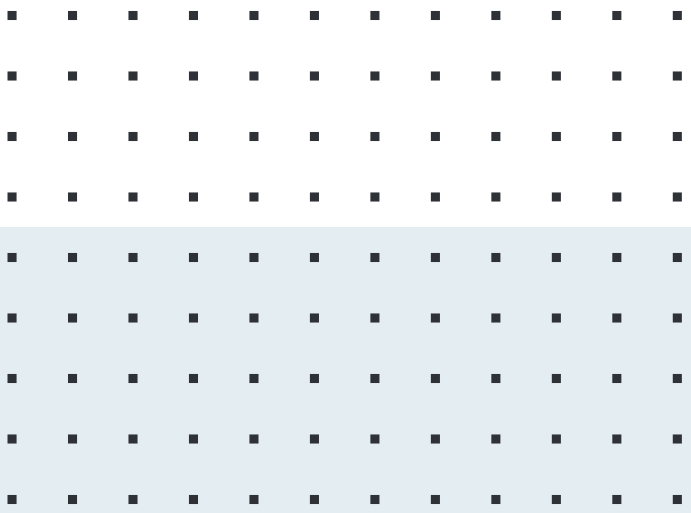



Machine type

Bandsaw BEKAMAK BMSY 440 DGH

BEKAMAK BMSY 440 DGH bandsaw is a machine for cutting profiles, pipes and prisms. The machine is equipped with a hydraulic clamping system that holds the material during cutting, ensuring an accurate and even cut.

Technical data:

- cutting range of round elements: 440 mm,
- cutting range of rectangular elements: 610x440 mm at 90°,
- angle cut +/- 60° on 2 sides.





Machine type

Bandsaw BEKAMAK BMSY 320 DGH

The BMSY 320 DGH bandsaw is ideal for variable amounts of angled and straight cutting. The bandsaw has a rigid frame that ensures high cutting accuracy.

Technical data:

- cutting range of round elements: 320 mm,
- cutting range of rectangular elements: 450x320 at 90°.





Machine type

ERLO drilling machines

We use many machines in our fabrication department. Appropriate and functional equipment is key to achieving high product quality, as well as ensuring safety and production efficiency.

ERLO TSAR 25 drilling machine

- maximum drilling diameter for 70 kg/mm² steel: 25 mm,
- maximum threading capacity for 70 kg/mm² steel: M22.

ERLO TSAR 50 drilling machine

- maximum drilling diameter for 70 kg/mm² steel: 50 mm,
- maximum threading capacity for 70 kg/mm² steel: M36.

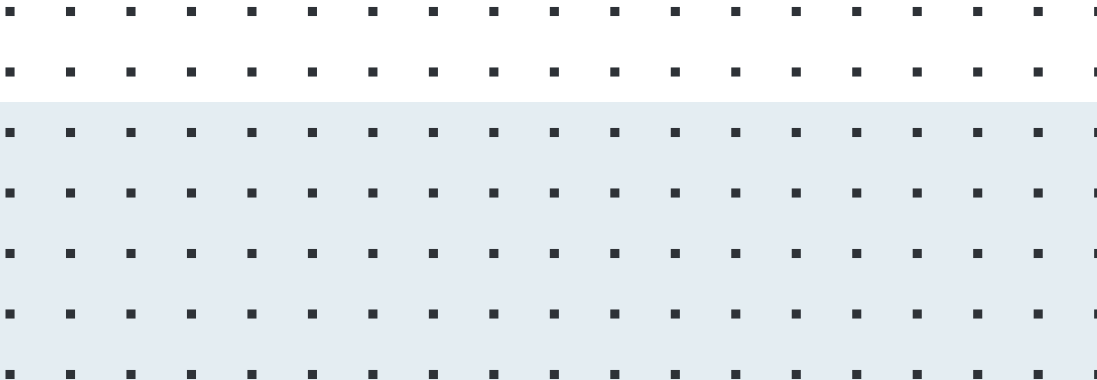

Did you know...?



Each month our specialised team processes

600 tons of steel





Quality control

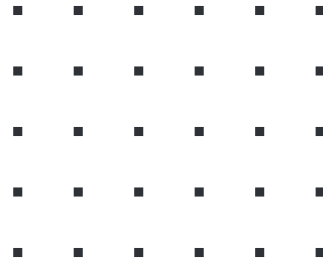

The quality control department is responsible for ensuring that production processes are correct, that they comply with defined quality standards, and that the quality of raw materials and materials used in production processes is monitored and controlled.

This department is essential to ensure that products and services comply with customer requirements and to guarantee that the company operates in accordance with regulations and safety standards.

An important element of the quality control department is also the documentation and reporting of quality control results. Any irregularities or deviations from standards are documented and analysed in order to find the causes of problems and take appropriate corrective action.

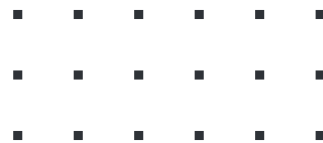



Machine type

Scanner 3D HandySCAN 3D|MAX Creaform

HandySCAN 3D MAX scanner is a mobile, metrology-grade 3D scanner, ideal for measuring large objects. The device is certified by an ISO 17025 accredited laboratory, confirming its precision at 0.075 mm + 0.010 mm/m based on the VDI/VDE 2634-3 standard. This allows for reliable measurement results and confidence during quality audits.

Technical data:

- measurement speed: 2,250,000 points/s,
- measurement field: 1x1 m,
- light source: 19 blue laser crosses,
- maximum permissible error (MPE): $(0.15 + L/4.95 \times 10^4)$ mm,
- scanning distance: 0.45 -1.6 m,
- measuring field depth: 1.15 m.

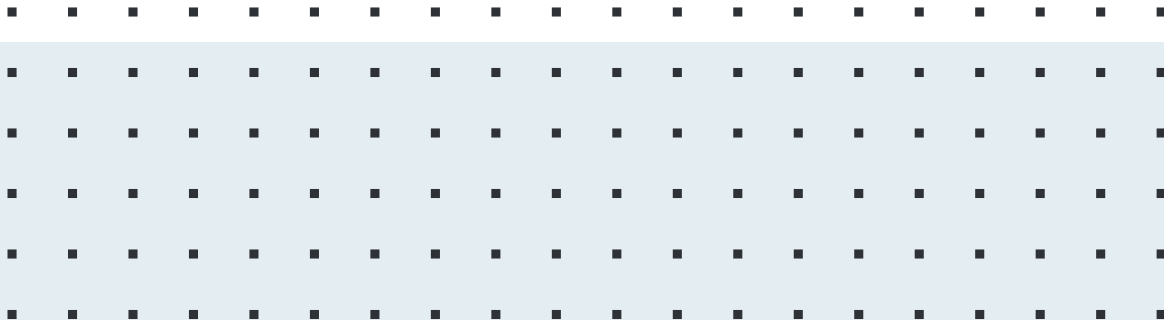



Machine type

Mitutoyo Crysta Apex V7106

Mitutoyo Crysta Apex V7106 measuring machine provides accurate volumetric measurements of complex components, significantly saving inspection time and allowing the measurement of objects that cannot be measured by traditional methods. With the PH10MQ measuring head from Renishaw, we can take angular measurements A/B 0-180st 0-(-180) 0-105 increments of 7.5 steps.

Technical data:

- accuracy: E0, MPE from: $(1,7+0,3L/100)$ μm ,
- travel speed: 519 mm/s (3 axes),
- 3D acceleration: 2 309 mm/s²,
- pressure = 0.4 MPa,
- range: 701 x 1000 x 600 mm.





Machine type

FARO Edge ScanArm 2.7

Accuracy is important in every single aspect of production, and 3D measuring technology is a prerequisite for ensuring this. Precision mechanics and laser measurements from FARO® prevent errors in applications such as setting machining jigs or aligning fixtures, part inspection, surface analysis, 3D modelling or as-built plant plan documentation.

Technical data:

- weight: 10.9 kg,
- 7-axis repeatability: 0.029 mm,
- 7-axis accuracy: +/- 0.041,
- arm, base plate, standard set (3mm, 6mm).

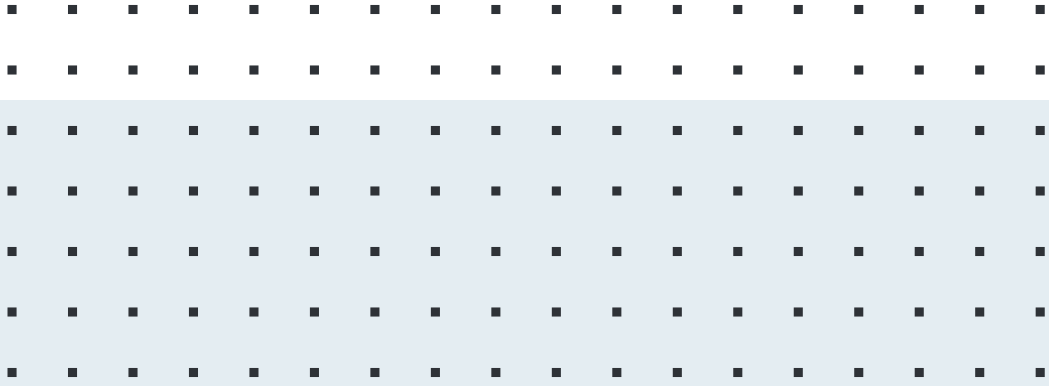



Design

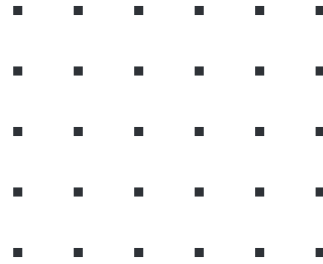

Our design office provides support when doing projects using AutoCad and Solid Edge 3D design software.

We operate on the basis of technical documentation provided by the customer as well as make designs based on the drawings and relevant assumptions submitted by the customer.

Every day, our team makes great efforts to ensure that customers receive offers in the shortest possible time. Our engineers approach projects individually, carefully analysing them and adapting to the needs of customers. This is one of the most important stage and the success of the further process of production of workpieces is determined by it. On many occasions, we have provided design support to our customers, both in terms of modifications and co-creation of new designs.



AutoCAD



Solid Edge

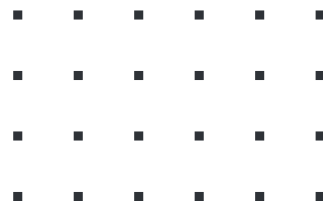



Cooperation

As regards comprehensive customer service, we offer a wide range of services in cooperation with partner companies.

Scope of cooperation:

- water cutting,
- plasma cutting,
- laser cutting and bending of workpieces with a length of more than 3 m,
- cutting and bending of pipes and profiles,
- wet painting,
- cataphoresis treatment,
- shot blasting,
- heat treatment,
- hot dip galvanising and electroplating,
- machining,
- rolling,
- electropolishing,
- and many other metalworking processes.

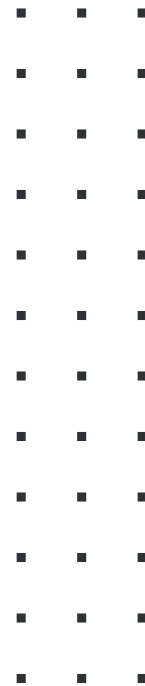

Green Globmetal

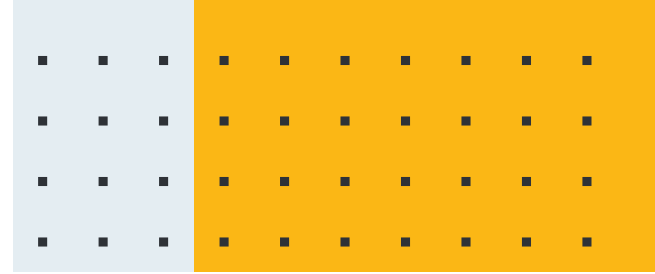

As a production company, we want to act in accordance with nature. That is why we are implementing a long-term plan activities aimed at developing our awareness, changing the tools we work on, and, consequently, make maximum use of renewable energy resources to reduce Co2 emissions. To live in harmony with nature, we work in accordance with the ISO 14001 and ISO 45001 standards.

- We have 100% electric powered wheelchairs,
- we invest in biodegradable machine coolants,
- we use photovoltaic energy,
- we invest in packaging made of recycled materials,
- we invest in biodegradable packaging,
- we segregate waste.

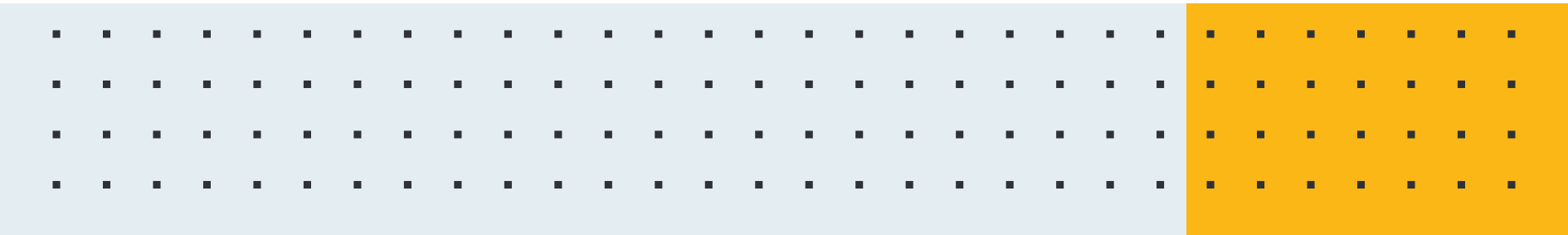

Stages of company development

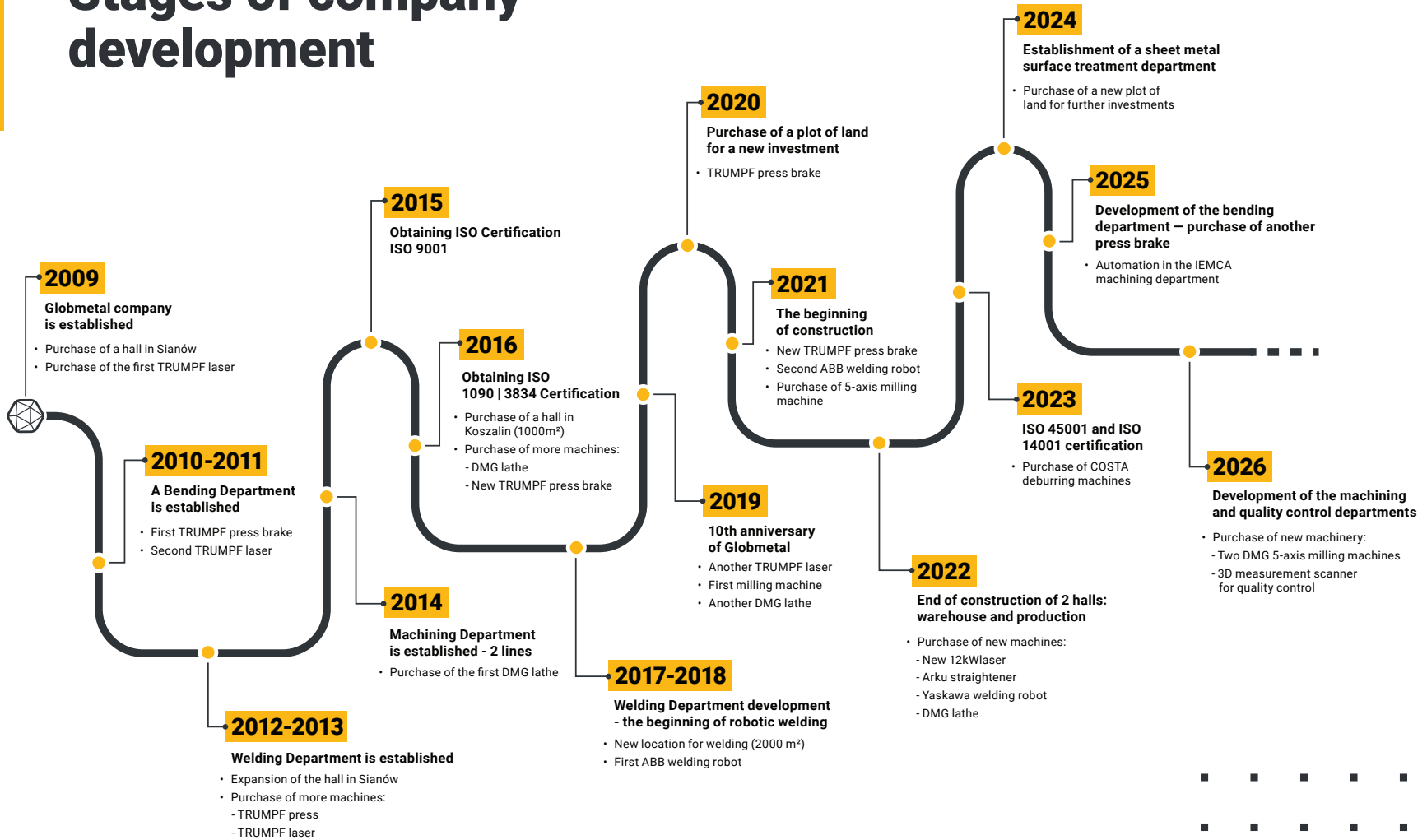



Globmetal



Ul. Inwestorska 5
75-845 Koszalin



+48 600 200 979
+48 94 318 55 99



biuro@globmetal.pl

globmetal.pl

